

KB S-50M & S-60M

Selfpropelled Mini-Scissors



Standardfeatures

- Working Height 5m and 6m
- Extendable Platform
- Non marking tyres
- Proportional controls for lift and drive function
- 25% Gradeability
- Manual Emergency lowering valve
- Multiple disc brakes
- Manual brake release
- Battery charger indicator
- Hour meter
- Forklift pockets
- Diagnostic System
- Beeper Horn
- Foldable Rails
- **Maintenance free batterie**
- 12 month warranty

Options

- AC wiring to platform
- 230V plug at the platform
- Working light
- Dual flashing beacon
- Airline to the platform
- Warranty extension



KB Liff

Luibl Lift GmbH

Industriestraße 18a

93176 Beratzhausen

info@kb-lift.com

www.kb-lift.com

info@luibl-lift.com

www.luibl-lift.com

Telefon: +49 851 / 75 68 68-0

Ust.ID-Nr: DE-323070148

Amtsgericht Regensburg HRB: 17063 IBAN: DE40 75070013

Institut: Deutsche Bank

SWIFT-BIC: DEUTDEMM750



a LUIBL product



Models KB Lift	S-50M	S-60M
Working height max (m) H1	5	6,4
Platform height max (m) H2	3	4,4
Outreach (m) (2)	0,55	0,55
Lifting capacity (kg)	240	240
Lifting capacity (kg) (Extended platform)	100	100
Weight(kg)	760	810
Platform size(3) x (5) x (6)(L x W x H)m	1,28 x 0,76 x 1,1	
The length of platform extended (m) (4)	1,8	1,8
Skirting board height (m) (7)	0,17	0,17
Stowed size(L x W) (8) x (9)m	1.49 x 0.76	1.49 x 0.76
Stowed height (m) (10)	2.03	2.03
Length of the machine with platform extended (m) (13)	-	-
Height of the machine with platform folded (m) (11)	1,5	1,59
Hydraulic tank capacity (L)	2	2
Gradeability	25%	25%
Wheelbase (m) (12)	1,05	1,05
Ground clearance (m)	0,06	0,06
Pothole protection board ground clearance (m) (down)	0,15	0,15
Inside rotation radius (m)	0,35m	0,35m
Outside turning radius (m)	-	-
Load number max	2	2
Raised time Lowenng time (s)	20/17	23/19
Traction speed (km/h)	3	3
Safe speed (km/h)	0,8	0,8
Vertical tilt°	3	3
Lateral tilt°	2	2
Power source	24V	
Tire size (mm)	Solid Non-marking tires 230	
Drive model	-	

References

The options determines the weight.

The working height (CE according) is 2 meters higher than the platform height.

All machines are equipped with CE declarations which is necessary for the use in Europe.

KB Lift provides machines with hydraulic drive (HD) and electrical drive (ED)

Furthermore KB Lift offers a big range of working platforms and fork lifts.

Working Height up to 6m

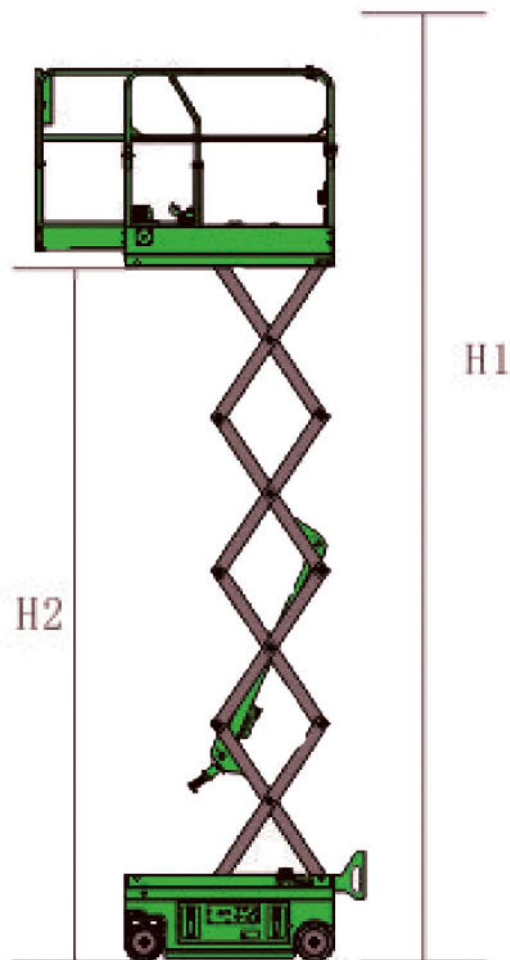

KB S-50M & S-60M

Dimensions

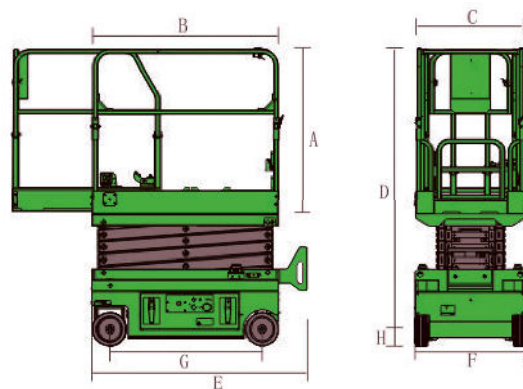

KB S-50M & S-60M