

TH 5,5.19

PRELIMINARY

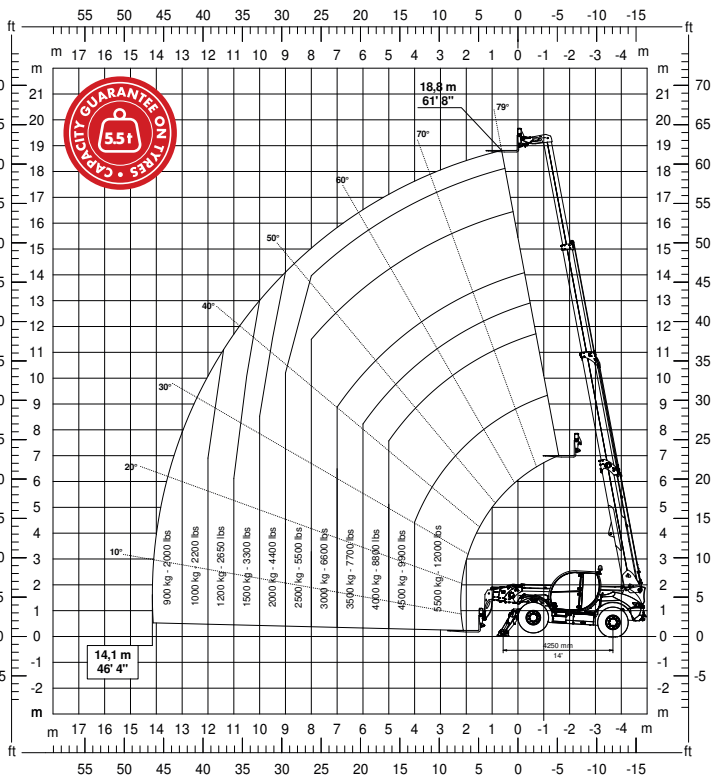

LOAD CHART WITH FORKS

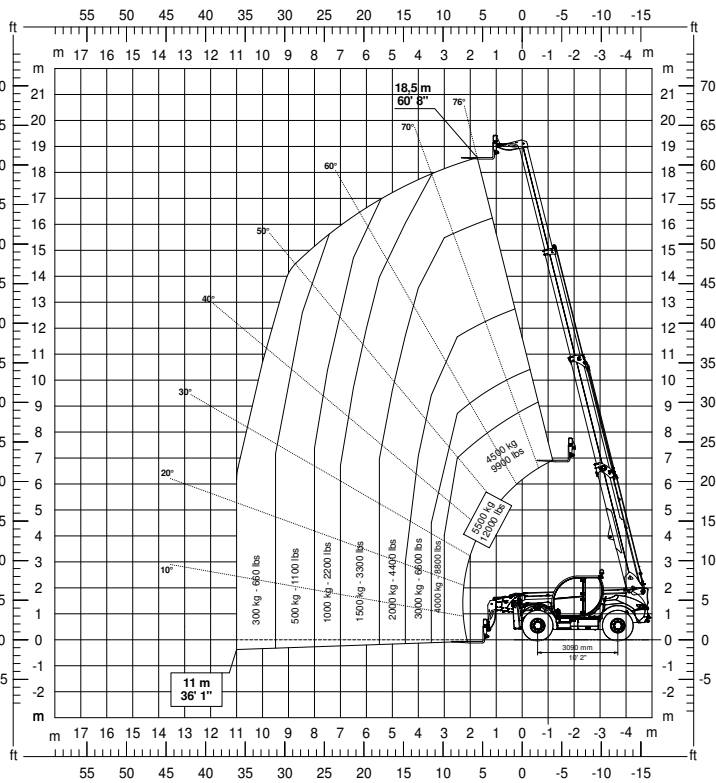

